

PLB | Mount Kit

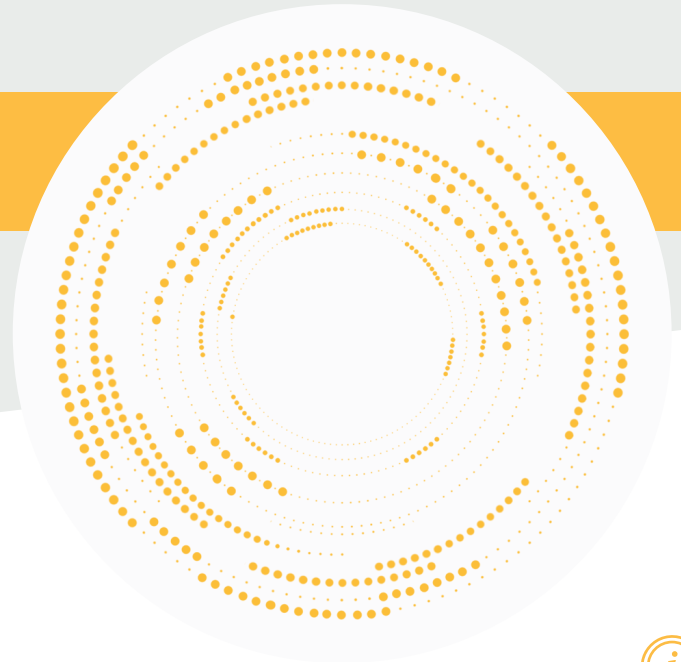

Product Description



The PLB Mount Kit maintains a stable measurement in weighing systems where vibrations and impact loads are present; eliminates problems arising from thermal expansion; corrects off-center loads; protects the load cell against leakage currents with a grounding cable.

Capacity Table



Kapasite	D	D1	D2	A	B	B1	C
250–12.500 Kg	156	131	119	79	12	10	10.5
15 Ton	168	143	130.3	82	12	10	10.5
30 Ton	194	169	156.3	100	16	14	10.5
50–100–120 Ton	296	230	230	144	20	20	22

Technical Dimensions and Drawings

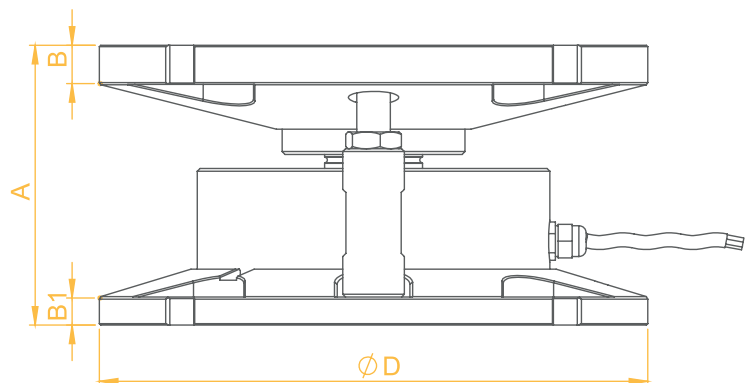
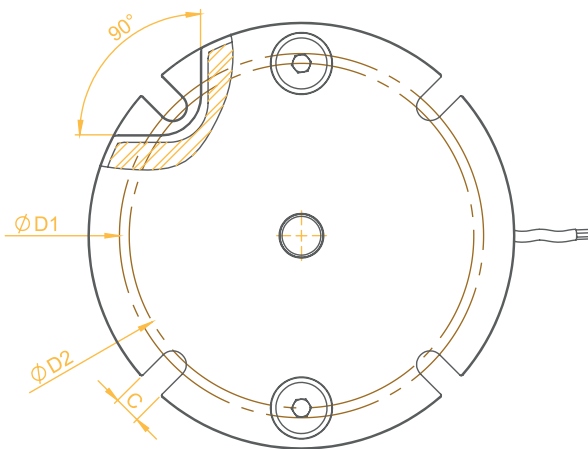

Application Areas

Tank and Silo Weighing



LPTSENS
Load Cell and Industrial Weighing Systems