

# STK | S Type Load Cell



## Product Description

The STK S Type Load Cell is designed to meet your high-precision measurement needs with capacity options ranging from 50 kg to 7500 kg. Its durable nickel-plated alloy or stainless steel body adapts to harsh industrial conditions, while its hermetic sealing feature ensures long-lasting and reliable use. The STK operates on the tension and compression principle.

## Technical Specifications

Capacity	50, 100, 300, 500 Kg 1, 2, 3, 5, 7.5 Ton	Insulation Resistance	≤ 5000 MΩ (100 VDC)
Accuracy Class	C3	Compensated Operating Temperature	-10 ~ +40 °C
Min. Load	0 kg	Operating Temperature	-30 ~ +70 °C
Max. Division Count (nLC)	3000	Recommended Excitation Voltage	10 VDC
Min. Measuring Range (Y=Emax / Vmin)	10000	Max. Excitation Voltage (Umax)	15 VDC
Total Error	±0.022 %FS	Overload Capacity	150 % FS
Output Gain (FS)	2.00 ± 0.005mV / V	Breaking Load	300 % FS
Zero Balance	±1 %FS	Protection Class	IP 66 / IP68
Input Resistance	380 Ω ± 20 Ω	Material	Steel / Stainless Steel
Output Resistance	350 Ω ± 3 Ω	Cable	4x022mm <sup>2</sup>

## Technical Dimensions and Drawings

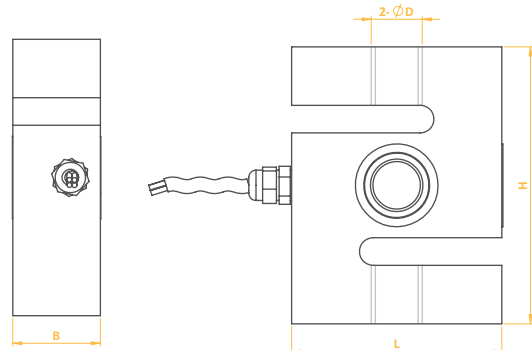
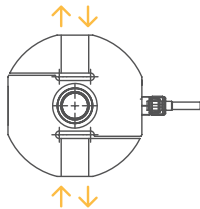
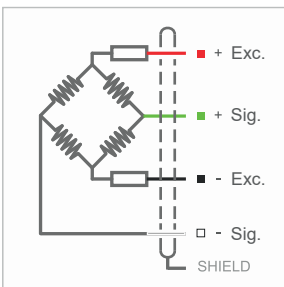

## Application Areas

- Crane Scales
- Tank and Bunker Weighing
- Mechanical Scale Conversions
- Compression and Tensile Force Tests

Capacity	ØD	L	H	B	Cable
50 - 100 - 750 Kg	M12	51	76.2	19.1	3,5 m.
1000 Kg	M12	51	76.2	25.4	3,5 m.
1500 - 7500 Kg	M20x1.5	76.2	100.4	31.8	5 m.

